

---

**NetworkAIR™ FM-CW**  
Computer Room Air-Conditioning—50 Hz



*Technical Data*



# Contents

---

<b>Overview</b> .....	<b>1</b>
<b>Scalable Solution for Critical Environments</b> .....	<b>2</b>
<b>Standard Features</b> .....	<b>4</b>
<b>Optional Features</b> .....	<b>5</b>
<b>Microprocessor Controller</b> .....	<b>7</b>
<b>Upflow models</b> .....	<b>8</b>
<b>Downflow models</b> .....	<b>10</b>
<b>Performance Specifications</b> .....	<b>12</b>
<b>Electrical Data</b> .....	<b>13</b>
<b>Dimensional Data</b> .....	<b>14</b>
<b>Piping Connections</b> .....	<b>20</b>
<b>Electrical Connections</b> .....	<b>21</b>
<b>Guide Specifications</b> .....	<b>23</b>
<b>Guidelines for Installation</b> .....	<b>31</b>

FM	Capacity (kW)	Module	Configuration	Voltage	Reheat	Humidifier	Air Pattern
FM	40	A=3 row 20 circuit coil B=4 row 20 circuit coil C=4 row 40 circuit coil	C=Chilled Water	GB= 400/3/50 FB= 400/400/3/50	F= Electric Reheat (High Output) X= No Reheat	S= Replaceable Steam Canister X= No Humidifier	D= Downflow  U= Upflow (front return) R= Upflow (rear return)
FM	XX	X	- X	XX -	X	X	X



# Overview

---

The modular, Floor Mount computer room air-conditioning system offers efficient, effective and economical cooling for a variety of spaces.

Computer room environmental requirements now reach far beyond the confines of the traditional data center or computer room to encompass a larger suite of applications, referred to as technology rooms. Critical environment applications include:

- Computer rooms
- Telecommunication facilities
- Clean rooms
- Power equipment
- Medical equipment rooms
- Archives
- LAN/WAN environments

A worldwide network of APC representatives is fully qualified to provide engineering, sales, installation and service for our products.

APC warrants all parts for 12 months from commissioning or 18 months from shipment, whichever comes first. Extended warranties are available.

## Capacity

The NetworkAIR FM chilled water configuration is available in 3 coil sizes: 3 row 20 circuit, 4 row 20 circuit, and 4 row 40 circuit.

## Room Air Distribution

Downflow systems discharge air into the raised floor plenum. These systems are suitable for areas with raised floors greater than 300 mm high. Return air is drawn in through the top of the system. Downflow systems incorporate insulated discharge ducts on supply air fans to aid static regain. This evens out velocity profile and increases static performance while reducing noise level. It also allows access to some components while the system is operating, without interrupting airflow.

Upflow systems discharge air into either a plenum or ductwork. These systems can be used when a raised floor does not exist or is not suitable for cooling. Air is drawn in through the front and optionally from the rear of the system.

The NetworkAIR FM delivers high volumes of airflow (265 m<sup>3</sup>/h per kW) to eliminate hot spots in densely populated environments.

## Configuration

- Chilled Water

## Compliance Approval

- CE



## Standard Features

- Direct Drive Motor/Fan
- Frequency Controlled Motor
- Electrical Panel
- Double Skin Panels
- Microprocessor Controller
- Programmable Input/Output Interface Module
- Main Power Circuit Breaker
- 94VO Thermal (anti-fungal) Drip Tray
- Predictive Failure Warnings
- Network Management Card
- Redundant Group Control
- 3-Way Modulating Valve

## Optional Features

- Replaceable Steam Humidifier
- SCR Controlled High Output Electric Reheat
- EU4 Filters
- EU7 Filters
- Plenums (with or without grilles)
- Floorstand
- Discharge Duct Collar
- Sub-Base
- Firestat
- Smoke Detector
- Flow Switch
- Spot/Cable Water Detector(s)
- Hot Water Reheat
- High Lift, Dual Float Condensate Pump
- Environmental Monitoring
- Dual Critical/Non-Critical Power Inputs
- Circuit Setter Read-Out

# Scalable Solution for Critical Environments

---

## **Temperature and Humidity Design Conditions**

Maintenance of temperature and humidity design conditions is critical to the smooth operation of a technology room. Design conditions should be 22-24°C and 45-50% relative humidity (R.H.). As damaging as the wrong maintained conditions can be, rapid temperature swings can also have a negative effect on hardware operation. This is one of the reasons hardware is left powered up, even when not processing data. Computer room air conditioning is designed to maintain temperature at  $\pm 1^\circ\text{C}$  and humidity at  $\pm 3\text{-}5\%$  R.H. 24 hours a day, 8760 hours a year. Vapor barriers and sealed rooms are required to maintain these tolerances.

In contrast, comfort systems are designed to maintain  $\pm 5^\circ\text{C}$  from the temperature setpoint. There is usually no dedicated humidity control and the simple controllers cannot maintain the set point tolerance required for temperature, allowing potentially harmful temperature and humidity swings to occur. This is not acceptable for sensitive electronic equipment.

## **Air Quality**

Computer room air conditioners provide a high air volume, around 265 m<sup>3</sup>/h per kW. This high air volume moves more air through the space improving air distribution and reducing the chance of localised hot spots. It also allows more air to move through filters, ensuring a cleaner environment. This requires a moderate- to high-efficiency filter bank to minimise airborne particles.

## **Problems Caused by the Wrong Environment**

A poorly maintained technology room environment will have a negative impact on computer room operations. The results can range from data corruption to complete system shutdowns and failures.

## **High & Low Temperature**

A high or low temperature swing or rapid temperature swings can corrupt data processing and shut down an entire system. Temperature variations can alter the electrical and physical characteristics of electronic chips and other board components, causing faulty operation or failure. These problems may be transient or may last for days. Transient problems can be very difficult to diagnose and repair.

## **High Humidity**

High humidity can result in tape and surface deterioration, head crashes, condensation, corrosion, paper handling problems and (gold and silver) migration leading to component and board failure.

## **Low Humidity**

Low humidity greatly increases the possibility of static electric discharges. Such static discharges can corrupt data and damage hardware.

## **APC NetworkAIR™ FM-The Right Solution**

The APC NetworkAIR™ FM provides the maximum amount of computer room cooling in a compact footprint. Highly scalable, the system is capable of growing with your cooling needs as they increase. Each system comes standard with concise capacity controls for high efficiency operation.

## **Compact Footprint**

The NetworkAIR FM delivers a high capacity of cooling in a small “overall” footprint. Since the system requires only front service access, units can be placed side by side and valuable floor space is not wasted.

**Humidity Control**

Increasing heat densities in data centers are leading to more hot spots and higher return temperatures to the precision air conditioners. When hot spots exist in close proximity to the air conditioner, temperature and humidity readings can be misleading to the overall room conditions. As temperature increases, the relative humidity (R.H.) level (the amount of moisture the air can hold at a given temperature, shown as a percentage) decreases. If the air conditioner is set to control on R.H., it will over humidify based on the higher return air temperature and lower R.H.. There are two methods of preventing this over-humidification. The most accurate way to achieve this is by changing the humidity set point on the controller to dew point control.

You can see from the horizontal line in the psychrometric chart that the dew point does not change as the dry bulb temperature increases from 23.8°C to 29.4°C. However, humidifying the room to maintain 45% R.H. would result in excess moisture content in the room. Another way to prevent over-humidification from hot spot fluctuations is through temperature and humidity averaging. This ensures that an outlying condition does not affect the overall room conditions. Individual hot spots should be addressed using heat removal architectures to address the problem at the rack level. See APC White Paper #55 for more information on air distribution architectures.

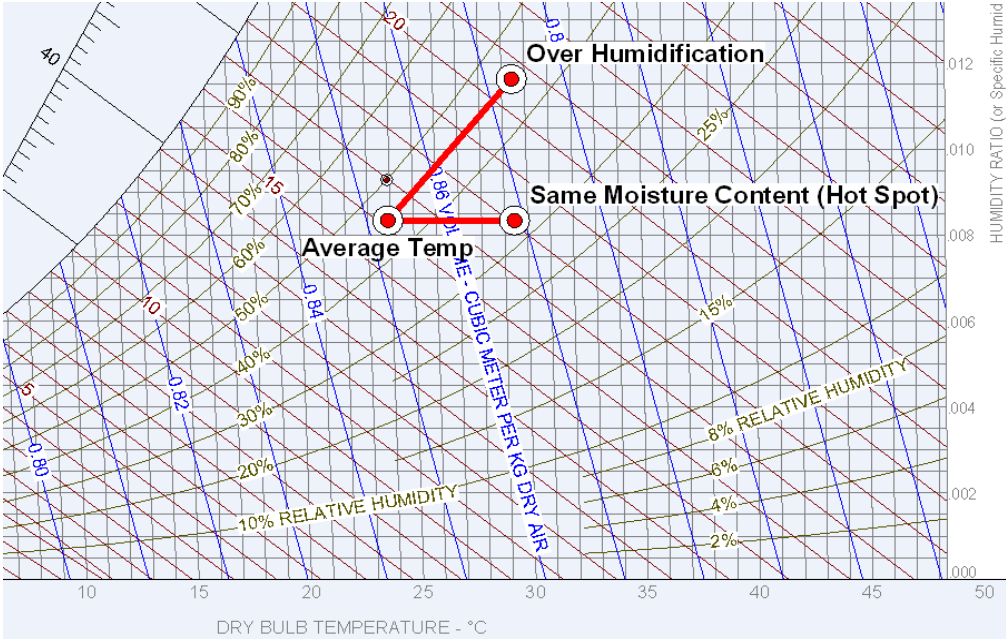

**Chilled Water Configuration**

Chilled water systems utilise water from a chiller plant for cooling. Chilled water is commonly used in large buildings and high rises and can serve multiple indoor units.

- System used with a chiller plant
- Cost effective for large installations

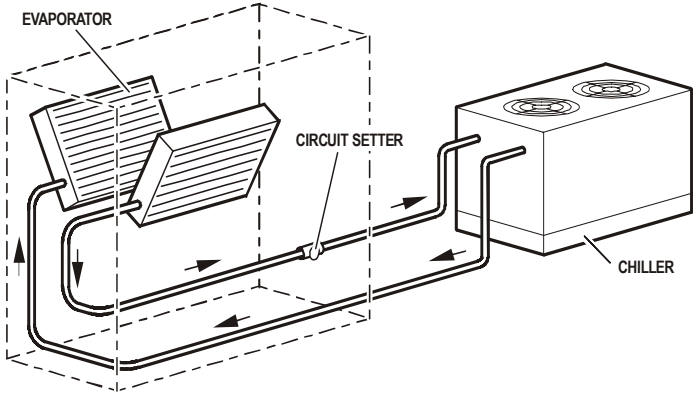

# Standard Features



## Double Skin Panels

The frame is bolt together 2.78mm formed steel for maximum strength. Cabinet is serviceable from the front. All exterior panels and corner posts on the frame are powder coated for durability and an attractive finish. Front exterior panel crowne is 1.59mm. All other panels are double skin, 0.635mm exterior, 0.635mm interior with 24kg/m<sup>3</sup> insulated for quiet operation. Insulation is CFC-free and recyclable. Double skin panels isolate insulation from the air stream and further reduce sound levels. Left and right front panels are hinged and removable for easy access. Middle panel is removable.

## Direct Drive Motor/Fan Assembly

Each cabinet includes precision balanced centrifugal fan assemblies that are balanced to less than 1 mil displacement on all axis for quiet, reliable operation. The fans are mounted based on mass and frequency to eliminate vibration and noise. A direct drive (L<sub>10</sub>-500,000 hour bearing life) motor and frequency controller are used with each fan in the system to enhance user functionality. Each FM is equipped with two fan assemblies.

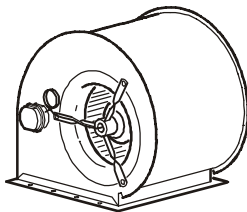

## Frequency Controlled Motor

A frequency controlled drive is installed for each direct drive fan motor. The frequency controller communicates with the microprocessor controller allowing user adjustable rpm settings via display. This makes field air balancing quick and easy. Field air balancing is a common after thought that can be expensive and lead to back-charges. Each time the fans are started, the frequency controlled drives control the ramp-up of fan speed. This thirty second soft start lowers the in-rush current and reduces the locked rotor amps used when sizing generators.

## Electrical Panel

The electrical panel contains the contactors, starters, overload protection devices, and input power disconnects.

## Cross Circuited Cooling Coil/ 94V0 Thermal Condensate Pan

Cross-circuited cooling coils connect to the incoming chilled water supply to provide greater sensitivity in cooling and dehumidification. Designed for high sensible heat ratios, the coil is constructed with copper tubes, aluminum fins, and galvanised steel end plates. Condensate pan is 94V0 thermal formed, anti-fungal, non-ferrous material for higher indoor air quality. Cooling coil is configured as V.

## Main Power Circuit Breaker(s)

A nonautomatic main power circuit breaker disconnects all high voltage power to the unit if necessary. The disconnect switch is accessible without removing the electric box cover.

## Programmable Input/Output Interface Module

The FM provides field connections through a system programmable input/output module. Up to three additional input/output interfaces may be added to the FM unit. Each interface module is programmable with inputs that can be mapped to any system alarm or annunciated to outputs as a system alarm or custom (12 character) alarm.

## Redundant Group Control

Allows up to 4 groups of FM units to communicate with each other for redundancy, demand fighting prevention, mode assist, and global sharing of certain settings. Requires standard network cable interconnection.

## Network Management Card

Permits multi-level access to monitoring, control, and event notification features over the user's network.

## Predictive Failure Warnings

Several components within the unit will provide a warning that service is needed prior to failure occurring.

## 3-Way Modulating Valve

A fully modulating valve is microprocessor controlled to automatically direct the proper amount of chilled water in the cooling coil to maintain desired conditions. A second 3-way valve may be manually adjusted for 2-way flow if so desired.

# Optional Features

---

## **Steam Generating Humidifier**

The humidifier utilizes a pure steam generator specifically designed for precision environmental control. The pure steam eliminates contaminating mineral deposits, potentially harmful bacteria, white dust and excessive humidity. Automatic flushing combined with a communication link to the controller signals when the canister is to be changed. Humidifier is proportionally controlled to meet the humidification demands of the conditioned space. The communication link to the main controller provides diagnostic capability for the humidifier.

## **EU4 Filters**

The filtration of conditioned air is extremely vital to maintaining the clean, particle-free environment required by electrical equipment. The system uses EU4 filters (100 microns), 102 mm deep, with full depth filter pleats. Deeper filters produce a lower pressure drop, requiring less energy during normal operation. Filters are replaceable through the front of the upflow unit, and through the top of the downflow unit.

## **EU7 High Efficiency Filter(s)**

A pleated, EU7 final filter, 102mm deep, allows the removal of a greater percentage of airborne particulate contaminants.

## **SCR Controlled Electric Reheat**

Each unit comes with two stage, high output, SCR electric reheat. Electric reheat elements are low watt density, wired for 3-phase and loaded equally on all three phases, SCR controlled, and electrically and thermally protected by both automatic and manual reset thermal cut outs.

## **Cable Water Detector**

A leak detection cable is placed on the floor or subfloor around all possible leak sources. If water or other conductive liquids contact the cable anywhere along its length, the master controller visually and audibly announces a leak. The 12m cable may be cascaded to make custom lengths up to 300m. A maximum of four detectors (spot or cable) may be installed.

## **Spot Water Detector(s)**

The solid-state spot water detector activates an audible alarm on the controller when moisture is detected. A maximum of four detectors (spot or cable) may be installed.

## **Firestat**

A firestat is available for factory installation in the return air stream of the unit. If the return air temperature reaches 52°C, an audible and visual alarm on the microprocessor will be activated and the unit will immediately shutdown.

## **Smoke Detector**

The factory-installed smoke detector is designed to sense smoke in the return air stream. Upon detection of smoke, an audible and visual alarm on the microprocessor will be activated and the unit will be immediately shutdown.

## **High Lift, Dual Float Condensate Pump**

The factory installed and wired condensate pump is capable of pumping 0.06 L/s at 18.3m head.

## **Flow Switch**

In-line paddle type flow switch placed in pipe during installation allows alarm or other control function to occur should a loss of chilled water flow be experienced.

## **Circuit Setter Read-Out**

Provides correlation of an observed differential pressure with a volumetric flow rate of chilled water for installation and service assistance.

## **Network Cable**

Various lengths of network cable are available to ship with your cooling system. Network cable is used to interconnect multiple cooling units in a redundant group, as well as to connect the network management card to your LAN.

## **Floorstand**

The floorstand raises the unit above the subfloor to match the height of the raised floor. Floorstands are equipped with air deflectors and turning vanes for optimal air distribution. Heights are available (from 300mm to 600mm) in 76mm increments and are adjustable +/- 38mm. Adjustment is provided by threaded pedestals. Vibration absorbing pads are included. The floorstand, pedestal, and pads ship loose.

## **Discharge Duct Collar**

A 25.4 mm duct flange is shipped loose from the factory for field installation to provide connection to external ductwork for either supply or return as needed.

**Plenums**

Discharge plenums are available on upflow and downflow systems. On upflow configurations, heights are offered in 510mm and 610mm with front, 2-sided, or 3-sided grilles. On downflow configurations, the plenum raises the unit by 350 mm and discharges air horizontally from the front of the plenum. This application is recommended in rooms where racks are positioned in hot aisle/cold aisle configurations. Discharge air should be ducted down cold aisles.

**Additional Programmable Input/Output Interface Modules**

Each system is equipped with up to 3 additional discrete input/output modules for a total of 16 input/outputs. Each interface module is programmable with outputs that can map from any system alarm through the microprocessor controller. Inputs are capable of mapping to outputs as a system alarm or custom alarm.

**Environmental Monitoring Unit**

A stand-alone unit performs contact monitoring and continuous temperature and humidity sensing through two probes (one included). The unit is controlled by available web, control console, or SNMP interface with a network connection. In the event of an environmental anomaly, notification is sent via e-mail or SNMP. The unit is 464mm x 229mm x 70mm. The probes extend up to 3.66m from the unit.

**Environmental Management System**

A browser-accessible, 1U, rack-mountable appliance allows monitoring of environmental conditions. Monitoring of one temperature, one humidity, and one vibration sensor ship standard. When conditions change, notifications are sent via email to appropriate personnel. The EMS provides 8 input contacts, 2 output relays, and controllable power outlets for defining actions remotely should conditions warrant it.

**Dual Critical/Non-Critical Power Inputs**

The system can be optionally configured with two power feeds for critical and non-critical operation. Fans, controller, compressor, and condensate pump are critical, while electric reheat and humidification are non-critical. This allows a level of system fault tolerance and uninterruptible cooling to exist depending on the building infrastructure design.

**Sub-Base**

The Sub-Base raises the height of the unit by 254mm on upflow units to provide access for electrical and piping connections. Front and rear access panels on the sub-base are removable.

# Microprocessor Controller

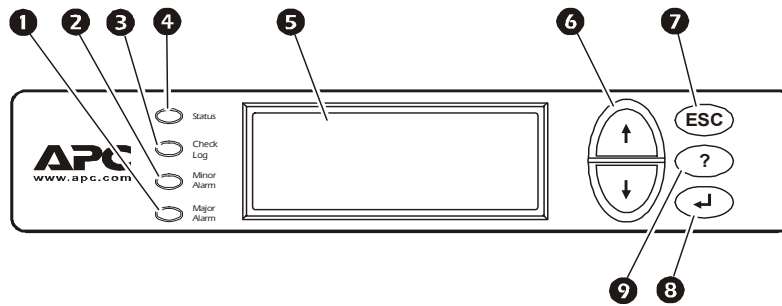

1	Alarm LED
2	Warning LED
3	Check Log LED
4	System On LED
5	Liquid Crystal Display (LCD)
6	Menu Selection scroll keys
7	ESC key
8	Enter key
9	Help key

## Microprocessor Controller

The microprocessor controller is standard on each system. The controller provides precision control for the demanding requirements of:

- Data centers
- Control rooms
- Clean rooms
- Switch rooms
- UPS rooms

The easy-to-use display allows the operator to select options from the device's menu-driven interface to control and monitor the connected air conditioning system.

## Open Architecture

The NetworkAIR FM protocol is open for integration with all building management systems. Communication interface on the system can be MODBUS RTU RS485.

## Control Type

Controller utilises proportional and integral derivative (PID), a time proven precision environmental control method. This allows for custom tuning of control variables to achieve desired system response.

## Functions

- Status Report
- System Control
- Event Logging
- Redundant Unit Group
- Static Pressure Adjustment

## Logging

The microprocessor displays the 64 most recent alarms. Each alarm log contains a time/date stamp as well as operating conditions at the time of occurrence. The controller also displays run time, in hours, for major components (compressors, heaters, humidifier, fan motors).

## Control

The backlit, four-line x twenty-character display is password configurable.

- Temperature Setpoint 15-32°C
- Humidity Setpoint 30-80% R.H.
- Fan Motor Setpoint 20-50Hz. (Factory preset for model size and options.)
- High Temperature Alarm 2-32°C
- Low Temperature Alarm 2-32°C
- High Humidity Alarm 15-85% RH
- Low Humidity Alarm 15-85% RH

## Customer Interface Modules

Each unit comes equipped with up to 3 additional discrete input/output modules. Each interface module is programmable with outputs that can map from any system alarm through the microprocessor controller. Inputs are capable of mapping to outputs as a system alarm or custom alarm.

## Alarms

- High control temperature
- Low control temperature
- High control humidity
- Low control humidity
- Clogged filter
- Return sensor failure
- High supply temperature
- Low supply temperature
- Loss or low airflow
- Loss of water flow
- Supply sensor failure
- Humidifier failure
- Replace humidifier canister
- Frequency controller failure
- Air block interlock open
- Water detected
- Fire (thermal sensor trip)
- Smoke detected
- Condensate pump failure

# Upflow models

---

## FM Upflow Components - Outside

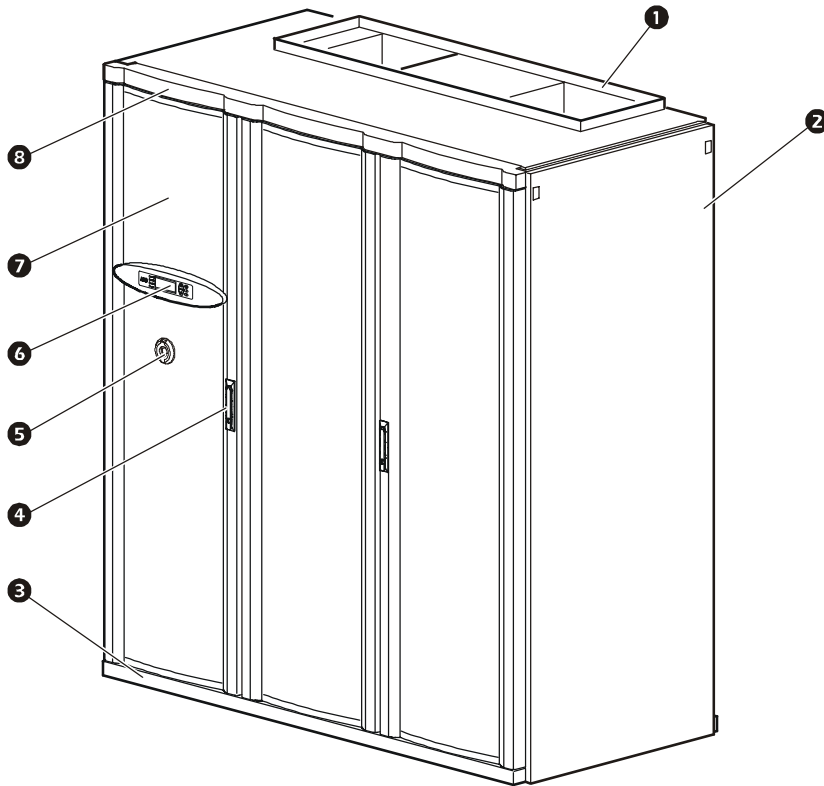

- |                          |                               |
|--------------------------|-------------------------------|
| ❶ Duct collar (optional) | ❺ Main power interrupt switch |
| ❷ Removable Side panel   | ❻ Display interface           |
| ❸ Kick-Panel             | ❼ Front door                  |
| ❹ Front door handle      | ❽ Door header                 |

## FM Upflow Components - Inside

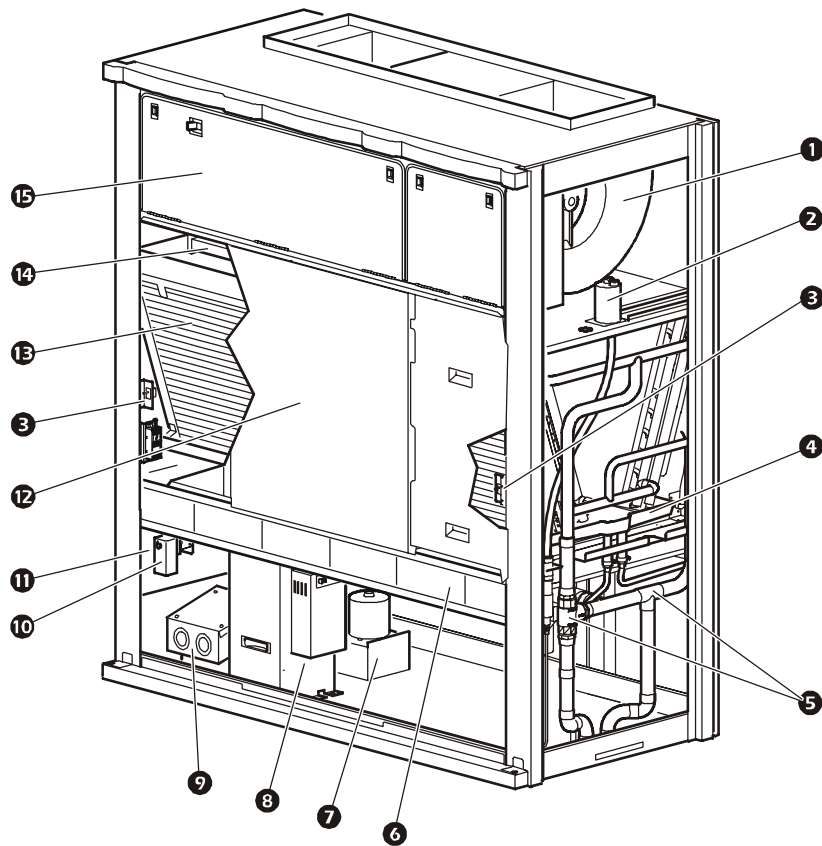

- |                              |                                   |
|------------------------------|-----------------------------------|
| ① Motor and fan assembly (2) | ⑨ Power distribution box          |
| ② Steam head                 | ⑩ Firestat (optional)             |
| ③ Fan interlock switch (2)   | ⑪ User interface box              |
| ④ Condensate pan             | ⑫ Front air blocks                |
| ⑤ 3-way ball valve           | ⑬ Cooling coil                    |
| ⑥ Air filters                | ⑭ Electric reheat coil (optional) |
| ⑦ Condensate pump (optional) | ⑮ Electrical panel                |
| ⑧ Humidifier (optional)      |                                   |

# Downflow models

---

## FM Downflow Components - Outside

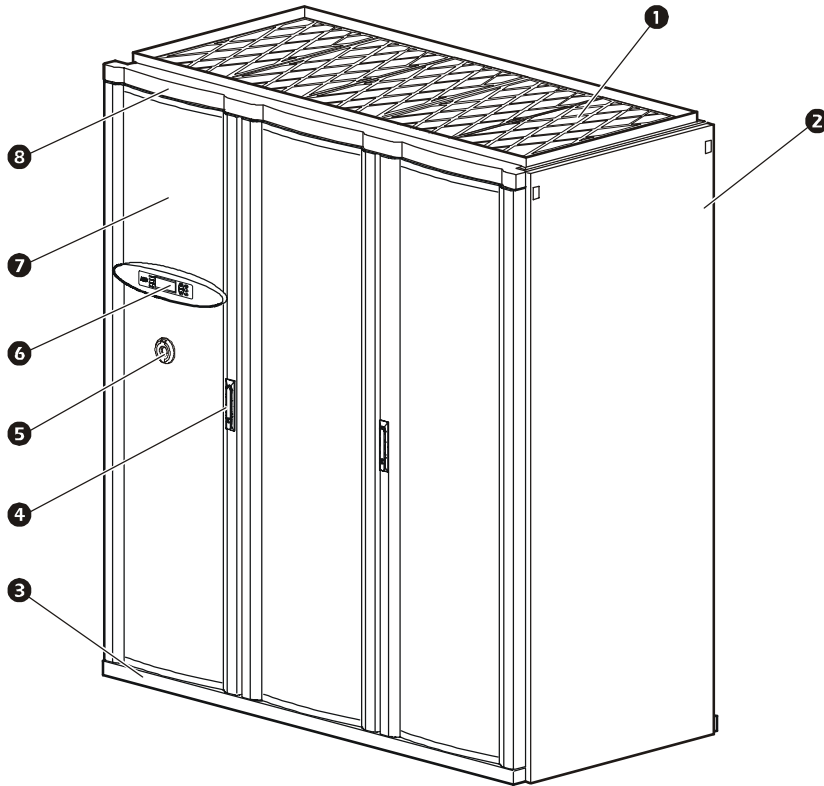

- |                        |                               |
|------------------------|-------------------------------|
| ❶ Air filters          | ❺ Main power interrupt switch |
| ❷ Removable Side panel | ❻ Display interface           |
| ❸ Kick-Panel           | ❼ Front door                  |
| ❹ Front door handle    | ❽ Door header                 |

## FM Downflow Components - Inside

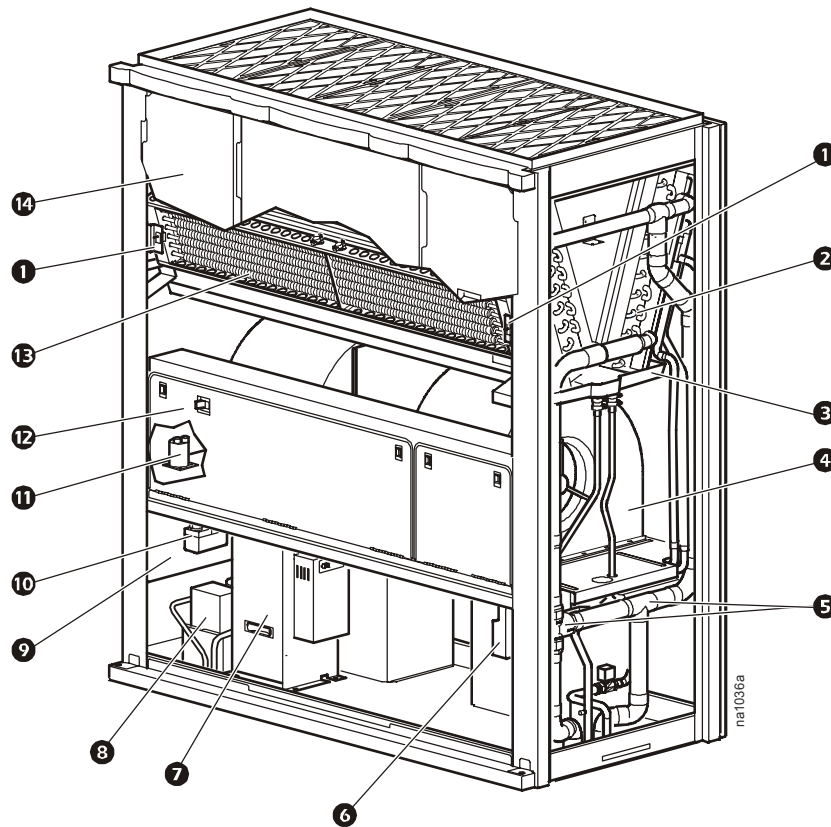

- |                              |                                   |
|------------------------------|-----------------------------------|
| ❶ Fan interlock switch (2)   | ❸ Condensate pump (optional)      |
| ❷ Cooling coil               | ❹ User interface box              |
| ❹ Condensate pan             | ❺ Firestat (optional)             |
| ❺ Motor and fan assembly (2) | ❻ Steam head                      |
| ❻ 3-way ball valve           | ❼ Electrical panel                |
| ❼ Actuator                   | ❽ Electric reheat coil (optional) |
| ❼ Humidifier (optional)      | ❾ Front air blocks                |

# Performance Specifications

NET COOLING MODE CAPACITY - kW @ 7.2C EWT*	3 Row 20 circuit	4 Row 20 circuit	4 Row 40 circuit
<b>26.7C DB, 19.4C WB 50% RH</b>			
Total	N/A	N/A	69.9
Sensible	N/A	N/A	50.6
Flow Rate - L/s	N/A	N/A	3.5
Pressure Drop - kPa	N/A	N/A	41
<b>23.9C DB, 16.9C WB 50% RH</b>			
Total	51.9	N/A	47.3
Sensible	45.0	N/A	42.6
Flow Rate - L/s	2.4	N/A	2.4
Pressure Drop - kPa	46	N/A	20
<b>23.9C DB, 16.1C WB 45% RH</b>			
Total	49.9	N/A	42.0
Sensible	47.3	N/A	42.0
Flow Rate - L/s	2.3	N/A	2.1
Pressure Drop - kPa	45	N/A	16
<b>22.2C DB, 15.5C WB 50% RH</b>			
Total	42.6	55.0	33.0
Sensible	40.3	47.3	33.0
Flow Rate - L/s	2.0	2.6	1.6
Pressure Drop - kPa	31	52	11
<b>22.2C DB, 14.8C WB 45% RH</b>			
Total	38.9	53.9	32.9
Sensible	38.9	50.3	32.9
Flow Rate - L/s	1.8	2.6	1.6
Pressure Drop - kPa	28	50	11
<b>21.1C DB, 14.8C WB 50% RH</b>			
Total	33.9	49.6	26.3
Sensible	33.9	44.3	26.3
Flow Rate - L/s	1.6	2.3	1.3
Pressure Drop - kPa	23	45	7
<b>21.1C DB, 14.0C WB 45% RH</b>			
Total	33.6	41.3	26.3
Sensible	33.6	41.3	26.3
Flow Rate - L/s	1.6	2.0	1.3
Pressure Drop - kPa	23	31	7
<b>MODULATING VALVES</b>			
Size -- 3 Way Ball Valve -- Inches, NPT (Cv)	1-1/2 (161)	1-1/2 (161)	2 (249)
<b>AIR SYSTEM -- DIRECT DRIVE CENTRIFUGAL</b>			
Air Volume -- L/s	3,775	3,775	3,775
Fan Motor -- kW	3.72	3.72	3.72
External Static Pressure -- Pa	125	125	125
Number of Fans	2	2	2
<b>COOLING COIL -- V FRAME, COPPER TUBE/ALUMINIUM FIN</b>			
Face Area -- m <sup>2</sup>	1.93	1.93	1.93
Rows Deep	3	4	4
Face Velocity -- m/s	1.9	1.9	1.9
<b>HUMIDIFICATION --- SOLID STATE ELECTRODE CANISTER</b>			
Flush Cycle	automatic	automatic	automatic
Capacity -- Kg/hr	4.53	4.53	4.53
kW	3.2	3.2	3.2
<b>FILTERS</b>			
Quantity	5	5	5
Size -- mm	325x737	325x737	325x737
Depth -- mm	100.8	100.8	100.8
<b>REHEAT</b>			
<b>Electric -- Equally Loaded Three (3) Phase, Finned Tubular, Low-Watt Density - SCR Controlled</b>			
Capacity -- kW Includes Motor Heat**	20.1	20.1	20.1
Stages	2	2	2
<b>PHYSICAL DATA</b>			
Weight -- kg	1012	1012	1012
Height -- mm	1,953	1,953	1,953
Length -- mm	1,800	1,800	1,800
Depth -- mm	889	889	889
<b>CONNECTION SIZES***</b>			
Chilled Water In/Out -- Inches	1-1/2	1-1/2	2
Humidifier			
Supply Line -- Inches	1/4	1/4	1/4
Condensate Drain			
Drain Line -- Inches	1/2	1/2	1/2

\*Max flow is 2.8 L/s for the 3 row 20 and 4 row 20 coils and 4.9 L/s for the 4 row 40 coil

\*\*With equal loading on each phase, rated at 400V / 3-phase

\*\*\*Connection Sizes, not recommended pipe sizes

# Electrical Data

## CHILLED WATER

REHEAT	Electric	None	Electric	None
HUMIDIFIER	Electrode Canister - Steam	Electrode Canister - Steam	None	None
VOLTAGE - MAIN	400	400	400	400
VOLTAGE - UPS	400	400	400	400
<b>FM Single Input</b>				
Combined	FLA	37.8	17.3	37.8
	RLA	42.5	21.0	42.5
<b>FM Dual Input</b>				
Non-Critical (Main)	FLA	25.3	4.8	25.3
	RLA	25.3	4.8	25.3
Critical (UPS)	FLA	12.5	12.5	12.5
	RLA	17.2	17.2	17.2

\*FLA= Full Load Amps, RLA=Rated Load Amps

The NetworkAIR FM product has the capability of splitting out the electrical input from a single electrical input to two electrical inputs. The total load draw for the system remains the same with one input supplying power to all critical loads and one input supplying power for all non-critical loads. In some cases, a two input system may be preferred as a means of supplying UPS power to critical loads. Single input = One electrical input for the system for all internal electrical loads. Dual Input is divided into non-critical and critical loads. Non-critical = This input supplies power to all internal loads that are not considered critical during a loss of utility power. Non-Critical loads include the humidifier and electric reheat. Critical = This input supplies power to all internal loads that are considered critical. Critical loads include the controller, condensate pump, and fans.

# Dimensional Data

## FM downflow

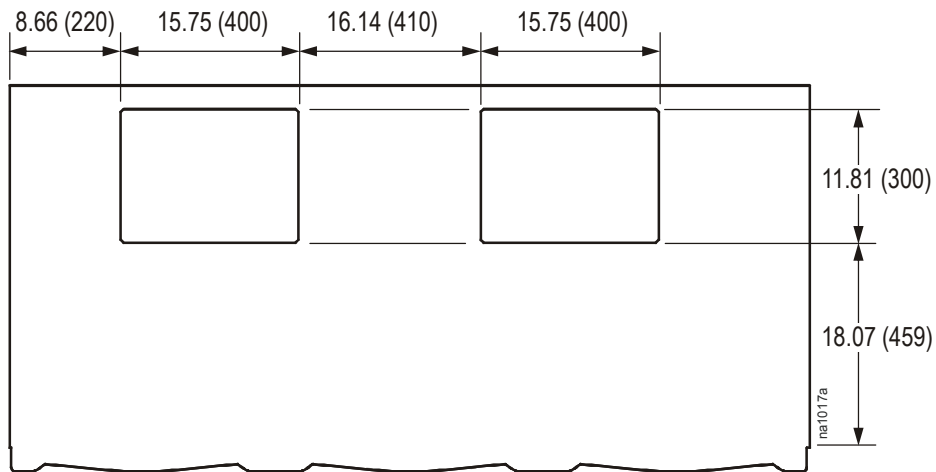
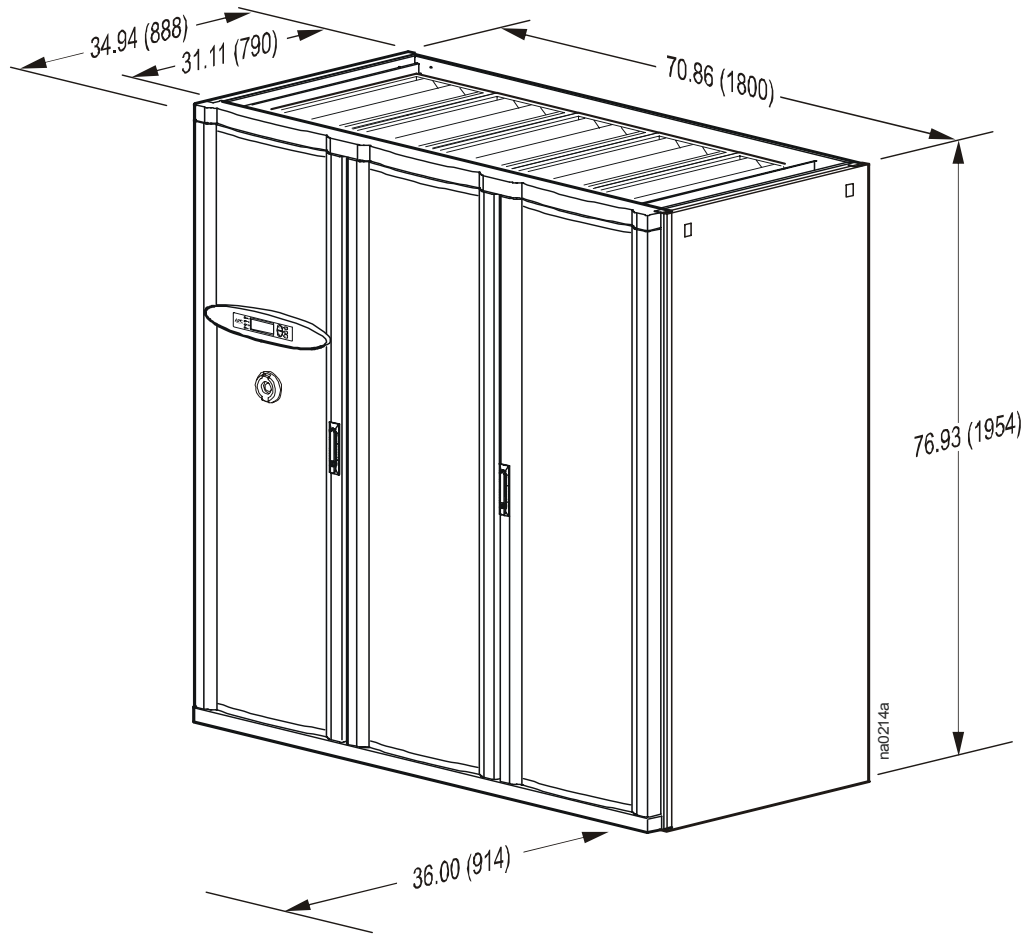

\* All dimensions are in inches (mm).

### FM upflow

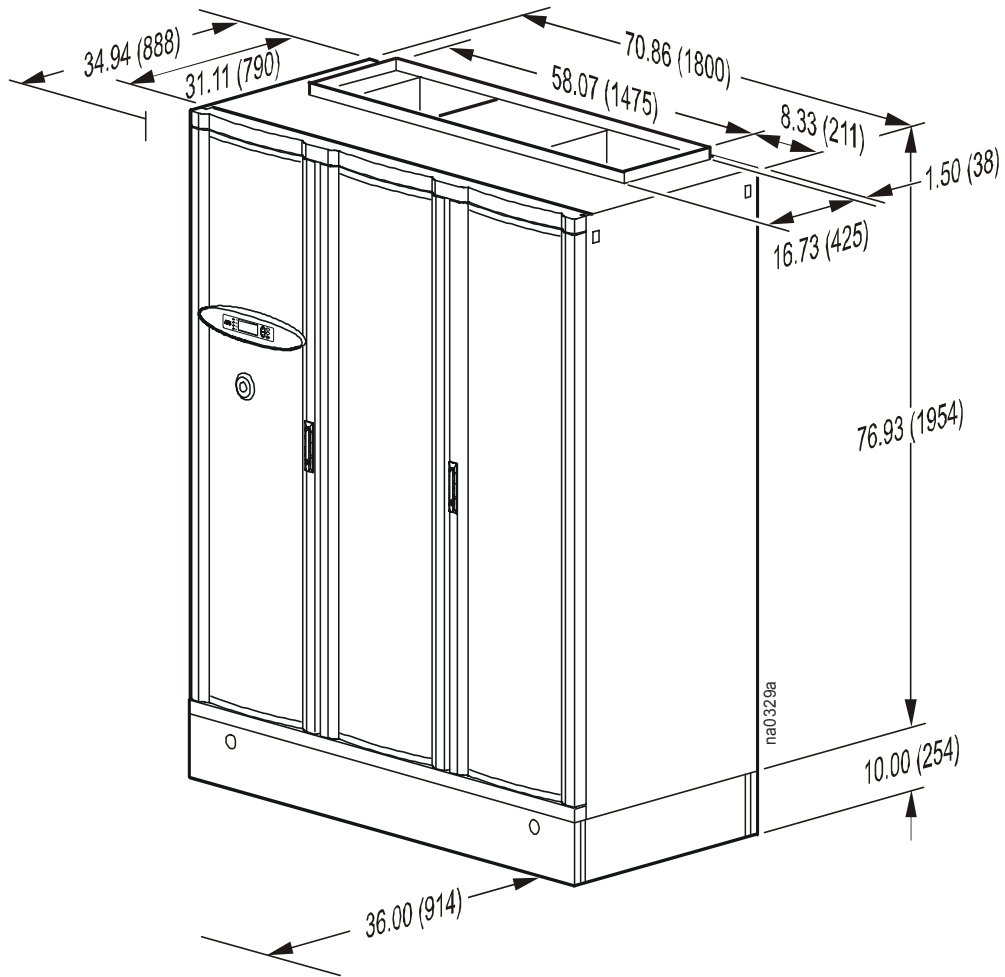

\* All dimensions are in inches (mm).

### FM upflow, rear-return

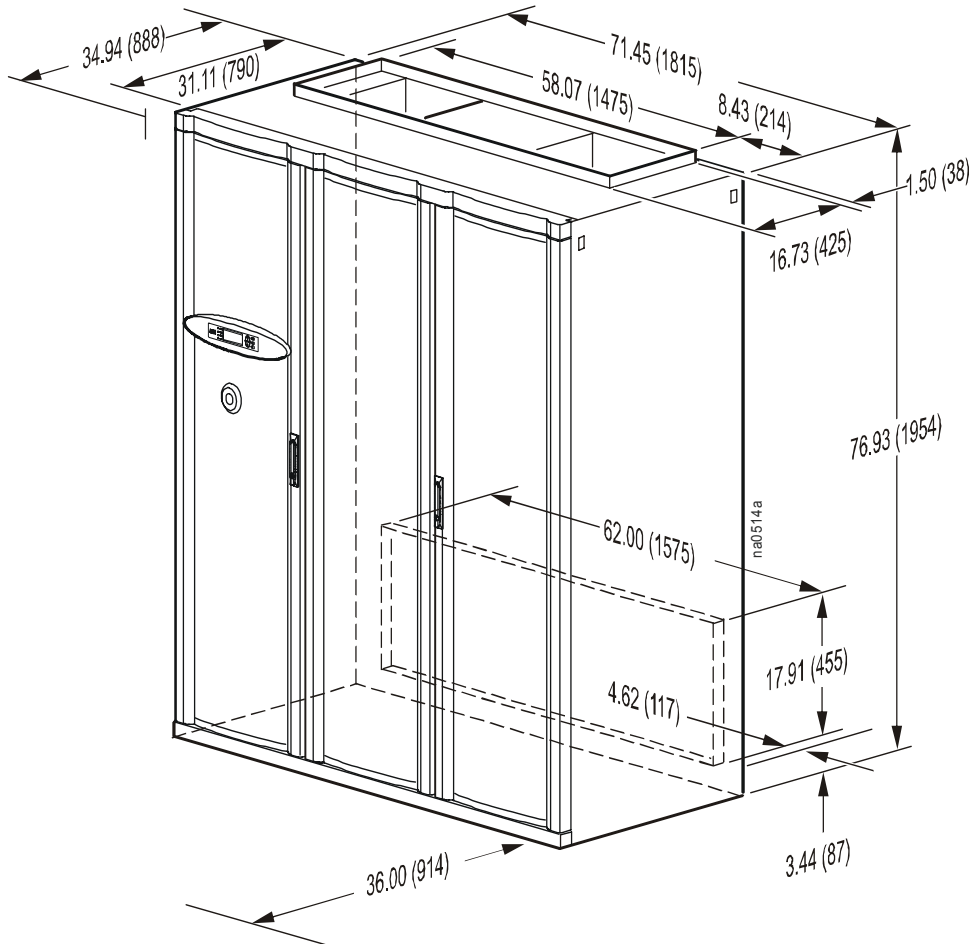

\* All dimensions are in inches (mm).

### FM Floorstand

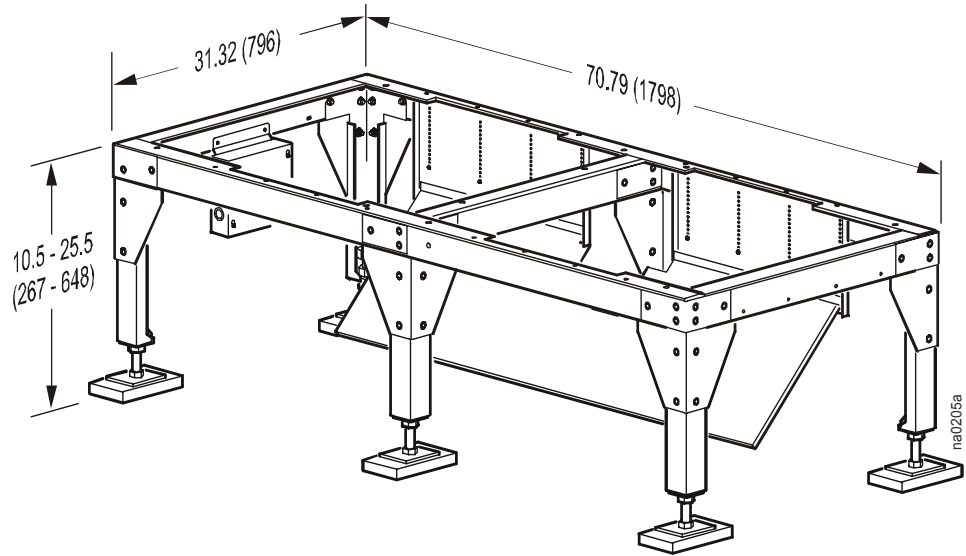

### FM Sub-Base

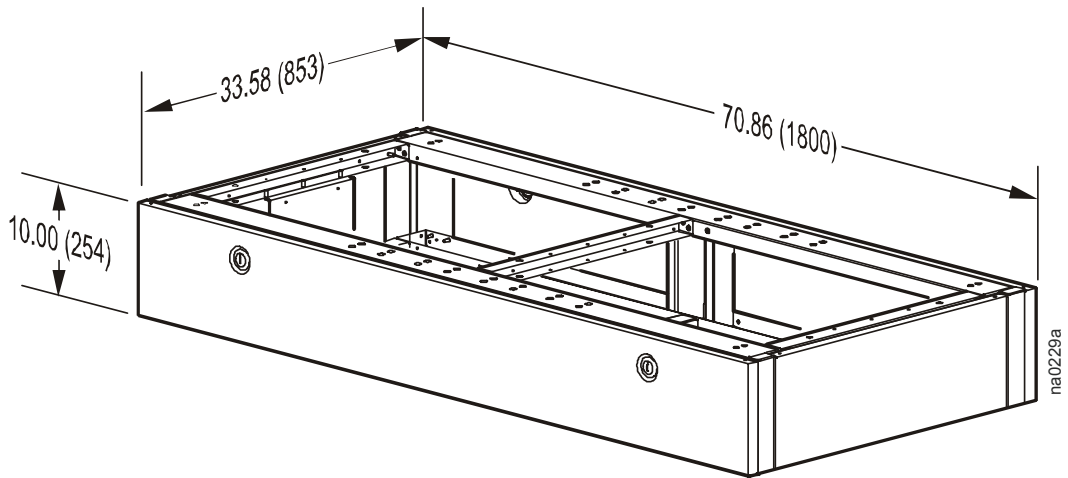

### FM 20" Plenum

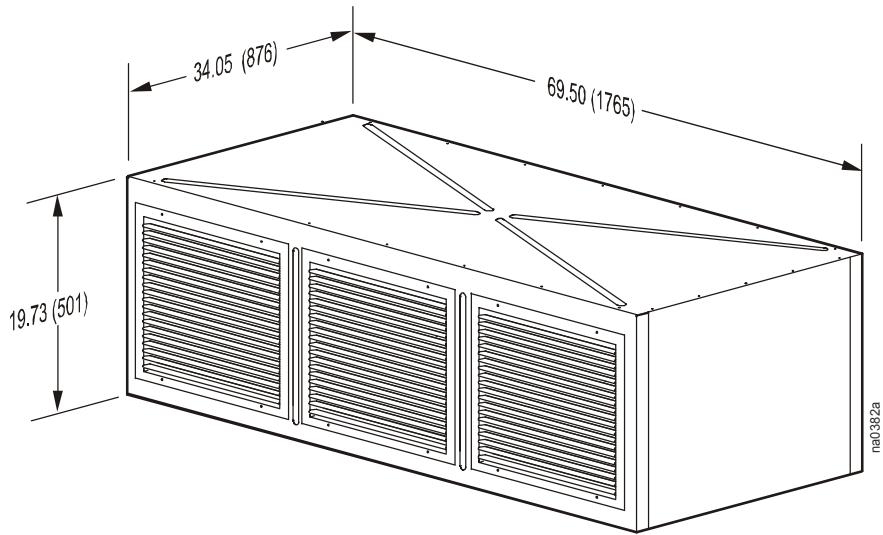

### FM 24" Plenum

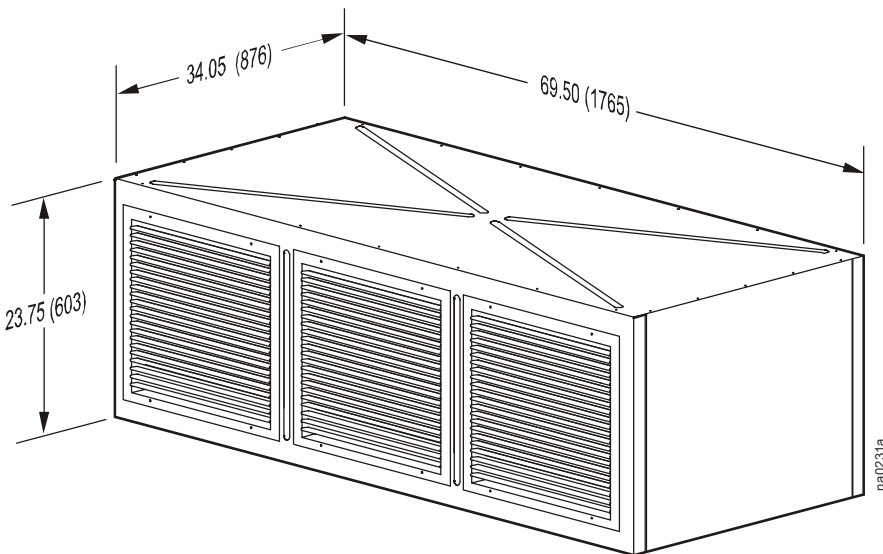

## FM Downflow Plenum

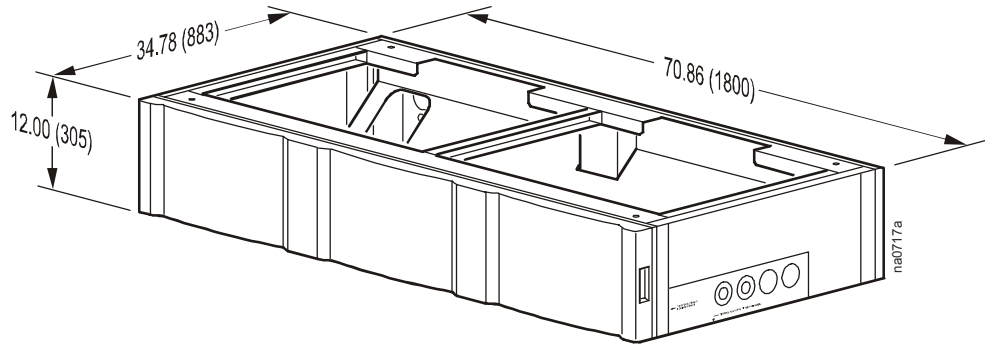

# Piping Connections

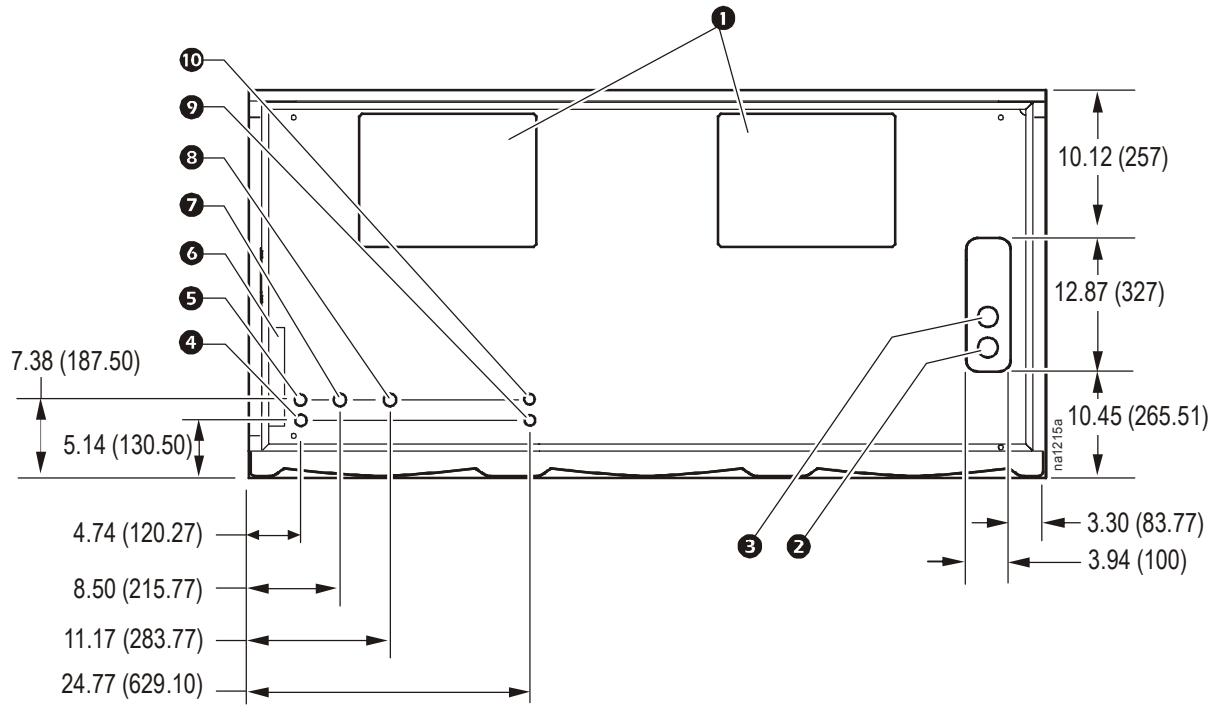

- |                               |                             |
|-------------------------------|-----------------------------|
| ❶ Air outlets (downflow only) | ❸ Control interface box     |
| ❷ Water in                    | ❹ UPS power                 |
| ❸ Water out                   | ❺ Condensate drain          |
| ❹ Control interface access    | ❻ Additional control access |
| ❺ Main power                  | ❼ Humidifier fill           |

# Electrical Connections

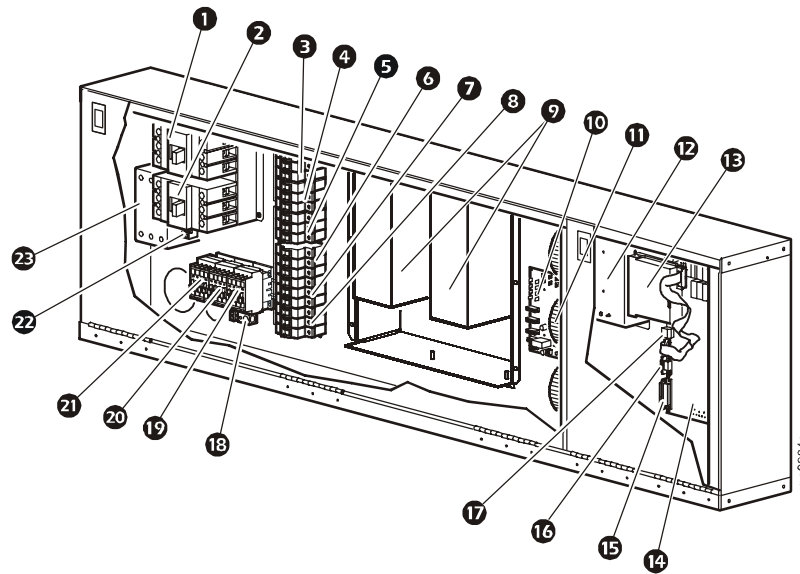

- |  |                                |
|--|--------------------------------|
| ❶ Input circuit breaker—UPS power          | ❸ Card slot                    |
| ❷ Input circuit breaker—main power         | ❹ Controller board             |
| ❸ VFD 1 circuit breaker                    | ❺ DB25 (user interface)        |
| ❹ VFD 2 circuit breaker                    | ❻ Console port                 |
| ❺ Controller circuit breaker               | ❼ Display interface connection |
| ❻ Heater 1 circuit breaker                 | ❽ Ground lug                   |
| ❼ Heater 2 circuit breaker                 | ❾ Humidify contactor           |
| ❽ Humidifier circuit breaker               | ❿ Heat 2 contactor             |
| ❾ Fan motor inverter/frequency controllers | ⓫ Heat 1 contactor             |
| ❿ Voltage selector board                   | ⓬ Ground lug                   |
| ⓫ Control transformer                      | ⓭ Reheat SCR control           |
| ⓬ Smoke detector                           |                                |



# Guide Specifications

---

## PART 1 — PART 1 GENERAL

### 1.01 SUMMARY

- A. The environmental control system shall be designed specifically for precision temperature and humidity control applications. It will automatically monitor and control heating, cooling, humidifying, dehumidifying, and filtering functions for the conditioned space. The system shall be built to the highest quality engineering and manufacturing standards, and shall be floor mounted and configured for \_\_\_\_ (up/down/up rr) discharge of conditioned airflow, with draw-through air pattern, to provide uniform air distribution over the entire face of the coil.

### 1.02 DESIGN REQUIREMENTS

- A. The system shall be as described in the following specification as manufactured by APC.
  - 1. Model: \_\_\_\_\_.
  - 2. Total cooling capacity: \_\_\_\_\_ kW.
  - 3. Sensible cooling capacity: \_\_\_\_\_ kW.
  - 4. Return air temperature: \_\_\_\_\_ ° C DB.
  - 5. Return air temperature: \_\_\_\_\_ ° C WB.
  - 6. Humidity: \_\_\_\_\_ % RH.
  - 7. Air quantity: \_\_\_\_\_ L/s.
  - 8. External Static Pressure \_\_\_\_\_ Pa.
  - 9. Humidifier capacity: \_\_\_\_\_ kg/hr.
  - 10. Electrical supply: 400 V, 3 ph, 50 Hz.

### 1.03 SUBMITTALS

- A. Submittals shall be provided with the proposal and shall include: capacity data, electrical data, physical data, electrical connection drawing, and piping connection drawing.

### 1.04 QUALITY ASSURANCE

- A. The system shall be completely factory-tested prior to shipment. Testing shall include, but not be limited to: complete pressure and leak testing to ensure system integrity, “Hi-Pot” test, and controls calibration and settings. Each system shall ship with a completed test report to verify completion of factory testing procedure. The system shall be CE compliant.

### 1.05 WARRANTY

- A. System parts shall be warranted for a period of 12 months from commissioning or 18 months from the date of shipment from the factory, whichever comes first.

## **PART 2 — PART 2 PRODUCT**

### **2.01 STANDARD COMPONENTS**

#### **A. CABINET CONSTRUCTION**

1. Double Skin Panels: Exterior panels shall be double-wall. 70mm thick metal with 70mm thick interior wall and insulated with 0.68kg density fiber insulation. Insulation shall be completely protected from the air stream by the panel wall or air blocks. Front exterior panel crown shall be 1.61mm thick. Front panels shall be powder coated and removable hinged with a locking handle. Exterior frame and panel colour shall have colour values: L = 14.02, a = 0.13, b = +3.68. Main besel colour shall have colour values: L = 13.44, a = .43, b = -2.63.
2. Frame: The frame shall be constructed of 2.78mm bolt-together formed steel for maximum strength. All units shall have full service access from the front allowing systems to be placed side by side.

#### **B. DIRECT DRIVE MOTOR/FAN ASSEMBLY**

1. Fan: The unit shall be configured for draw-through air pattern, to provide uniform air flow over the entire face of the coil. Each cabinet shall include, double-inlet, double-width centrifugal fan(s) assemblies with forward-curving blades, dynamically and statically balanced as a completed assembly to a maximum vibration level of two mils on all planes. Fans shall be mounted based on mass and frequency to minimise vibration and noise.
2. Frequency Controlled Motor: A direct drive motor and frequency controller shall be used with each fan in the system to enhance user functionality. The frequency controller shall communicate with the master controller via RS485 MODBUS communication link. The unit shall be equipped with two fans with a direct drive motor and a frequency controller for each motor.

#### **C. ELECTRICAL PANEL**

1. The electrical panel shall contain contactors, starters, overload protection devices, and input power disconnects. The panel shall be located in the front of the unit for available access.

#### **D. CROSS CIRCUITED COOLING COIL/94VO THERMAL CONDENSATE PAN**

1. The cooling coil shall use aluminum fins and rifle-bored copper tubes. Coil end-supports shall be galvanised steel.
2. The condensate pan shall have an overflow protection pipe. The overflow piping shall extend from the condensate pan to the base pan of the unit and allow for optional field piping such as a gravity drain.

## E. MASTER CONTROLLER

1. **Monitoring and Configuration:** The master display shall allow monitoring and configuration of the precision air conditioning unit through a menu-based control. Functions include status reporting, setup, and temp/humidity set points. Four LED report the operational status of the connected Precision air conditioning unit.
2. **Controls:** The microprocessor shall come equipped with control keys allowing the user to navigate between menus, to select menu items, and to input alphanumeric information.
3. **Alarms:** The microprocessor controller shall activate a visible and audible alarm in the occurrence of any of the following events:
  - a. High control temperature
  - b. Low control temperature
  - c. High control humidity
  - d. Low control humidity
  - e. High filter differential pressure
  - f. Return sensor failure
  - g. High supply temperature
  - h. Low supply temperature
  - i. Loss or low airflow
  - j. Supply sensor failure
  - k. Water regulator actuator failure (model specific)
  - l. High head pressure
  - m. Low suction pressure
  - n. Humidifier failure (model specific)
  - o. Replace canister (model specific)
  - p. Frequency Controller1 failure
  - q. Frequency Controller2 failure (model specific)
  - r. Air block interlock open
  - s. Water detected (optional)
  - t. Fire (thermal sensor trip--optional)
  - u. Smoke detected (model specific)
  - v. Condensate pump failure
4. **Logging:** The microprocessor controller shall log and display the 30 most recent alarms. Each alarm log shall contain time/date stamp as well as operating conditions at the time of occurrence. Controller shall display the run time hours for major components (compressors, heaters, humidifier, fan motors).

## F. PROGRAMMABLE INPUT/OUTPUT INTERFACE MODULE

1. The FM shall provide field connection through a system programmable input/output module. Each interface module shall be programmable with outputs that can map from any system alarm through the microprocessor controller. Inputs shall be capable of mapping to outputs as a system alarm or custom alarm.

G. REDUNDANT GROUP CONTROL

1. Shall allow up to 4 groups of FM units to communicate with each other for redundancy, demand fighting prevention, mode assist, and global sharing of certain settings. RGC requires a ship-loose network cable interconnection.

H. 3-WAY MODULATING VALVE

1. A fully modulating valve shall be microprocessor controlled to automatically direct the proper amount of chilled water in the cooling coil to maintain desired conditions. A second 3-way valve may be manually adjusted for 2-way flow if so desired.

I. MAIN POWER CIRCUIT BREAKERS

1. A factory installed, non-automatic main power circuit breaker shall disconnect all high voltage power to the unit if necessary. The disconnect switch shall be accessible without removing the electric box cover.

J. NETWORK MANAGEMENT CARD

1. The network management card shall permit multi-level access to monitoring, control, and even notification features over the user's network.

K. PREDICTIVE FAILURE WARNINGS

1. Several components within the unit shall provide a warning via the microprocessor interface that service is needed prior to failure occurring.

L. HIGH RETURN AIR TEMPERATURE CAPABILITY

1. All NetworkAIR FM units shall be equipped to handle the high return air temperatures associated with today's high density applications.

2.02 OPTIONAL COMPONENTS

A. STEAM GENERATING HUMIDIFIER

1. Humidifier shall be able to modulate capacity. The humidifier shall be self-contained, steam-generating type, factory piped and wired, with disposable cylinder and automatic solid-state control circuit. The humidifier shall require little or no scheduled maintenance. Humidifier canisters shall be replaceable and/or cleanable or disposable. The humidifier controller shall communicate directly to the microprocessor controller and provide complete status and control at the operator interface.

B. EU4 FILTERS

1. The air filters shall be EU4 efficient. The full 102 mm deep, pleated filters shall be replaceable from the front of the unit.

C. SCR ELECTRIC REHEAT

1. Each unit shall be provided with two stage, high output, SCR electric reheat. Reheat elements shall be low watt density, wired for three-phase, loaded equally on all three phases and shall be electrically and thermally protected by both automatic and manual reset thermal cutouts. Reheat capacity shall be \_\_\_\_\_ kW, SCR controlled.

D. FLOORSTAND

1. The floorstand shall raise the unit above the subfloor to match the height of the raised floor. Floorstands shall be equipped with air deflectors and turning vanes for optimal air distribution. Heights shall be available from 305mm to 610mm for downflow units in 76mm increments and shall be adjustable +/- 38.1mm. Threaded pedestals shall provide adjustment. Vibration absorbing pads shall be included. The floorstand, pedestal and pads ship loose.

E. SUB-BASE

1. A sub-base shall raise the height of upflow units for electrical wiring and piping access. The height shall be 254mm. Access panels shall be provided in the front and rear of the sub-base with 1/4 turn latches for removal.

F. PLENUMS

1. A discharge plenum shall mount on top of an upflow unit to direct and distribute conditioned air. The plenum shall be manually adjustable with double deflecting grilles provided on 2, 3 or 4 sides.

G. DISCHARGE DUCT COLLAR

1. A 25 mm duct flange shall be provided for field installation on a unit to provide convenient connection to external ductwork.

H. HIGH LIFT, DUAL FLOAT CONDENSATE PUMP

1. Factory installed and wired condensate pump shall pump 0.06 L/s at 18.3m head.

I. ADDITIONAL PROGRAMMABLE INPUT/OUTPUT INTERFACE MODULES

1. Each system shall be equipped with up to 3 additional discrete input/output modules for a total of 16 inputs/outputs. Each interface module shall be programmable with outputs that can map from any system alarm through the microprocessor controller. Inputs shall be capable of mapping to outputs as a system alarm or custom alarm.

J. FIRESTAT

1. A firestat shall be factory-installed in the return air to sense heat and send a signal to the main controller shutting down the unit and activating a visual and audible alarm.

K. SMOKE DETECTOR

1. A smoke detector shall be factory-installed in the return air to sense concentrations of smoke and send a signal to the main controller shutting down the unit and activating a visual and audible alarm.

L. SPOT WATER DETECTOR(S)

1. A water detector shall be factory-wired and shipped in the bottom of the unit to sense water and send a signal to the master control giving the operator possible alarm indications options for shutdown. The water detector shall be provided with 5m of wire.

M. CABLE WATER DETECTOR

1. A leak detection sensing cable shall be shipped loose with the unit. If water or other conductive liquids contact the cable anywhere along its length, the main controller visually and audibly annunciates the leak.
2. The detector shall be provided with 12m of cable. Cable may be cascaded up to 300m.

N. EU7 HIGH EFFICIENCY FILTERS

1. Filters shall be EU7 efficient. The full 102 mm deep, pleated filters shall be replaceable from the front or top of the unit.

O. FLOW SWITCH

1. Single pole, double throw shall moderate fluid flow when it drops below the set flow rate. Flow switch shall ship loose for field installation.

P. CIRCUIT SETTER READ-OUT

1. Shall provide correlation of an observed differential pressure with a volumetric flow rate of chilled water for installation and service assistance.

Q. NETWORK CABLE - REDUNDANT GROUP CONTROL

1. Network cables shall be available in 7.6m, 15.2m, 30.5m, or 61m lengths to ship with your cooling system. The network cable shall be used to interconnect multiple cooling units in a redundant group, as well as to connect the network management card to your LAN.

R. ENVIRONMENTAL MONITORING AND MANAGEMENT

1. Environmental Monitoring Unit: A stand-alone unit shall perform continuous temperature and humidity sensing through two available probes and contact monitoring. Unit shall be controlled by available web, control console, or SNMP interface with network connection. In the event of an environmental anomaly, notification shall be sent to the customer via e-mail or SNMP. The unit shall be 18.25"x9"x2.75"(464mm x 229mm x 70mm).
2. Environmental Management System: A browser-accessible, 1U, rackmountable appliance shall allow monitoring of environmental conditions. Monitoring of one temperature, one humidity, and one vibration sensor shall ship standard. When conditions change, notifications shall be sent via email to the appropriate personnel. The EMS shall provide eight input contacts, 2 output relays, and controllable power outlets for defining actions remotely should conditions warrant it.

S. DUAL CRITICAL/NON-CRITICAL POWER INPUTS

1. The system shall be optionally configured with two power feeds for critical and non-critical operation. Power inputs shall allow a level of system fault tolerance and uninterruptible cooling to exist, depending on building infrastructure design. The inputs may be bridged if single input operation is desired.

**PART 3 — PART 3 INDIVIDUAL SYSTEMS**

**3.01 CHILLED WATER**

- A. The unit shall be piped in accordance with the highest commercial quality procedures. All pipe shall be copper, type “L”, insulated. All pipe forming shall be tool bent with proper bend radii to prevent tube flattening in the curve. The chilled water piping shall be insulated with closed cell neoprene thermal insulation. The chilled water flow shall be controlled by a 3-way valve with a 24 VDC motor. All piping connections shall be made at the rear of the unit for top or bottom accessibility.

# Guidelines for Installation

---

The NetworkAIR FM provides reliable, accurate temperature and humidity control of computer rooms, laboratories, and other environments that require close tolerance control. The unit incorporates the latest system design innovations to provide you with optimum efficiency, reliability, and accuracy of control.

The NetworkAIR FM system will provide years of trouble-free service, when installed and maintained by technically qualified personnel.

## Room preparation

During the design of the room, consideration should be given to the following factors: ease of entry for the system, floor-loading factors, and accessibility of piping and wiring.

The room must be sealed with a vapor barrier to minimise migration of moisture. Polyethylene film (plastic sheeting) is a good vapor barrier for ceiling and wall applications. Rubber- or plastic-based paints should be applied to concrete floors and walls. The room should be thoroughly insulated to minimise thermal loads and make-up air (if required) should be preconditioned to reduce additional temperature, filtration, and moisture loads.

A room using a raised-floor plenum for air distribution should have at least 9" (300 mm) of clear space between the false floor and sub-floor for a finished floor height of 12" (380 mm). Pay special attention to the location of pipe chases, electrical conduits and other obstructions under the floor. These objects can block air circulation and cause loss of air pressure, thus reducing system efficiency and causing hot spots in your room.

Minimum clear space of 18" (460 mm) is to be provided for units over 15 tons (53 kW).

APC should be notified before installation if the unit is incorrect for the application.

## Unit location

The location of the unit is important for efficient and balanced environmental control in your room. The air conditioner should be located as close as possible to the largest heat load. In rooms having a high aspect ratio, mount the unit along the longest wall to ensure even air distribution. If improperly installed, erratic control or mechanical failure can and will result.

- Service access** At least 24" (610 mm) of clear space must be left in front of the unit for routine service (filters, humidifier). We strongly recommend approximately 32" (813 mm) clearance in front of the unit.
- Receiving the unit** Your NetworkAIR FM unit has been completely tested and inspected prior to shipment. To ensure that you have received the unit in excellent condition, perform a careful inspection of the crating and the unit immediately upon receipt. Verify that all parts ordered were received as specified and that the unit is the correct size and voltage necessary to fulfill your environmental control needs. Report any damage discovered to the freight carrier. If necessary, contact the APC field service department for help in repairing or replacing damaged parts. While APC is not responsible for damage incurred in transit, we want to make sure that you have no undue delays in your system start-up.
- Rigging** The unit is manufactured with a formed steel frame for maximum strength and unit integrity. However, as with all electrical and mechanical equipment, you must take care with proper rigging of your unit.
- When using a forklift to move the unit, use the shipping skid to protect the bottom of the unit. When using chains, cables or rope to lift the unit, use spreader bars to prevent damage to the finished panel.
- Floorstand** Install a threaded pedestal into each leg of the floorstand. Use the washer and nut on each panel to tighten against the floorstand leg.
- Utility connections** All connections are made through the bottom left of the unit (the left side of upflow discharge units) for ease of service connections. Refer to the installation manual for pipe sizes and specific locations for your unit.
- Power unit** The NetworkAIR FM unit uses 3-phase power for operation. Power connections are landed to a receptacle on either floorstand or sub base. Bring the service cable through the bottom left of the unit and through the bulkhead hole into the electrical box to the circuit breaker provided on the left side of the electrical box. The ground lug is located near the 3-phase high-voltage connector. **THE UNIT MUST BE UTILITY GROUNDED OR THE WARRANTY IS VOID.**
- Humidifier connections** The humidifier inlet connection point is provided with the equipment. A 1/4" (6.4mm) compression connection is supplied with the unit.
- Condensate drain** Condensate from the evaporator pan is collected and discharged by the condensate pump to a 7/8" (22.2mm) fitting for field connection.

**Water supply to humidifier**

1. The humidifier fill valve orifice is sized for supply water pressure from 15 PSIG (103.4 kPa) to 150 PSIG (1034 kPa).
2. For cases above 150 PSIG (1034 kPa), install a pressure-reducing valve in the water feed line to the unit.
3. With extremely dirty or muddy water sources, proper filtration is required on the unit's incoming water line.
4. DO NOT use softened water with the humidifier. Softened water is too conductive.
5. DO NOT use completely demineralised water with the humidifier. The minerals allow the electrode principle to work.
6. DO NOT use a hot water source. Doing so will cause deposits that will eventually block the fill valve orifices.
7. Water supplies with high conductivity (above 800 mW) must be preconditioned for proper operation and longevity of the humidifier.

**Note:** Because of an ongoing program dedicated to product improvement, specifications are subject to revisions without notice. APC assumes no responsibility, and disclaims all liability for damages resulting from use of this information or for any errors or omissions.







## APC Worldwide Customer Support

Customer support for this or any other APC product is available at no charge in any of the following ways:

- Visit the APC Web site to find answers to frequently asked questions (FAQs), to access documents in the APC Knowledge Base, and to submit customer support requests.
  - **www.apc.com** (Corporate Headquarters)  
Connect to localized APC Web sites for specific countries, each of which provides customer support information.
  - **www.apc.com/support/**  
Global support with FAQs, knowledge base, and e-support.
- Contact an APC Customer Support center by telephone or e-mail.
  - Regional centers:

APC headquarters U.S., Canada	(1)(800)800-4272 (toll free)
Latin America	(1)(401)789-5735 (USA)
Europe, Middle East, Africa	(353)(91)702020 (Ireland)
Asia Pacific	(61) 2 9955 9366 (Australia)

- Local, country-specific centers: go to **www.apc.com/support/contact** for contact information.

Contact the APC representative or other distributor from whom you purchased your APC product for information on how to obtain local customer support.

Entire contents copyright © 2005 American Power Conversion. All rights reserved. Reproduction in whole or in part without permission is prohibited. APC, the APC logo, and NetworkAIR are trademarks of American Power Conversion Corporation and may be registered in some jurisdictions. All other trademarks, product names, and corporate names are the property of their respective owners and are used for informational purposes only.